

Snorkellift®

ATB 42

ATB 50

Front oscillating axle and available 4 wheel drive, 4 wheel steer and crab steer, provide maximum rough terrain maneuverability

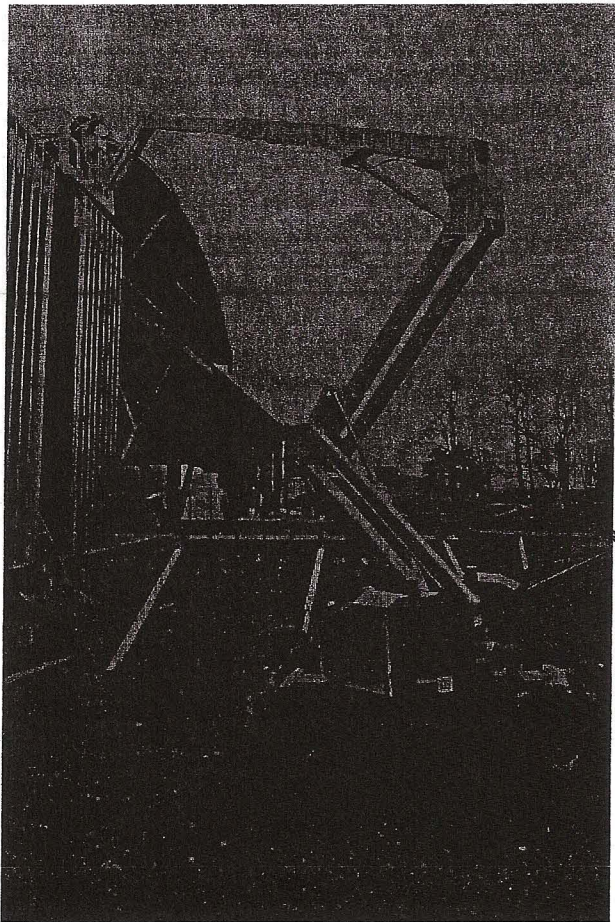

SPECIFICATIONS

	ATB 42	ATB 50
Working Height	48'7" (14.8 m)	56' (17.1 m)
Platform Height	42'7" (13.0 m)	50' (15.2 m)
Capacity	500 lbs. (227 kg)	
Size	72" x 30" (183 x 76 cm)	
Construction	High strength aluminum alloy	
Boom Construction	Steel	
Riser, Main & Jib Booms	High strength aluminum	
Telescoping Boom	High strength aluminum	
Boom Extension	Double acting hydraulic cylinder	
Boom Guides	Lubrication free, ultra high molecular weight polyethylene	
Pivot Pin Bearings	Lubrication free, composite material	
Horizontal Reach	20' 1" (6.1 m) at 24' (7.3 m)	28' (8.5 m) at 24' (7.3 m)
Elevation	+75°/-18°	
Jib Angle	+45°/-75°	
Hose & Wiring Extension	Telescoping housing attached to sides of booms	
Turntable Rotation	360° continuous	
Power Source	Gas (LP or Dual Fuel optional) or Diesel engine	
Fuel Capacity	15 US gal (56.7 L)	
Hydraulic System Capacity	16.5 US gal (62.4 L)	
Maximum Drive Speeds	High (booms stowed) Low (booms elevated)	
Gradeability	2 wheel drive 4 wheel drive	
Turning Radius (inside)	2 wheel steer 4 wheel steer	
Height (stowed)	6'11" (2.1 m)	
Width (stowed)	7'6" (2.3 m)	
Length (stowed)	20'8" (6.3 m)	21' (6.4 m)
Wheelbase	8' (2.4 m)	
Tires	12 x 16.5	
Type	8 ply rating	
Weight (approx.)	13,650 lbs (6,192 kg)	14,980 lbs. (6,795 kg)

- Front oscillating axle
- 4'6" articulated jib boom
- Fully proportional ramp-on control for drive
- Variable speed controlled boom functions
- Automatic braking
- Printed circuit board with on-board LED diagnostics
- Zero tailswing with boom elevated
- 180° hydraulic platform rotation
- 12 volt battery operated emergency power
- Driveable at full height
- 5° tilt alarm
- 125 volt GFCI AC outlet at platform
- Hour meter, ammeter and coolant temperature gauges
- Engine anti-restart control
- Hydraulic oil level and temperature gauges
- High engine temperature and low oil pressure shut-down system
- Keyed master switch
- Lifting and tie down lugs
- Filter minder
- Gravity gate on platform
- 60 month warranty

Snorkel

Snorkelift®

ATB 42 & ATB 50

Articulating, Telescoping Boom

Optional Equipment

- Vandalism protection (locking ground and platform control cover)
- Platform control box cover
- Operator horn
- Platform work lights
- Airline to platform
- Flashing light on boom
- Swinging gate
- Sandblast protection kit
- Dual fuel or LP gas only
- Cold weather start kit
- AC generator (hydraulic powered)
- Extra 12 volt battery
- Drive motion alarm
- All motion alarm
- Descent alarm
- Spark arrestor muffler
- BumpGard System
- 4 wheel steer
- 4 wheel steer with crab steer
- 4 wheel drive
- Large tires
- Foam filled tires
- Flotation tires
- Platform Option 96" x 30" (244 x 76 cm) Alum.

(The text in this area is intentionally blurred and illegible.)

ATB 42

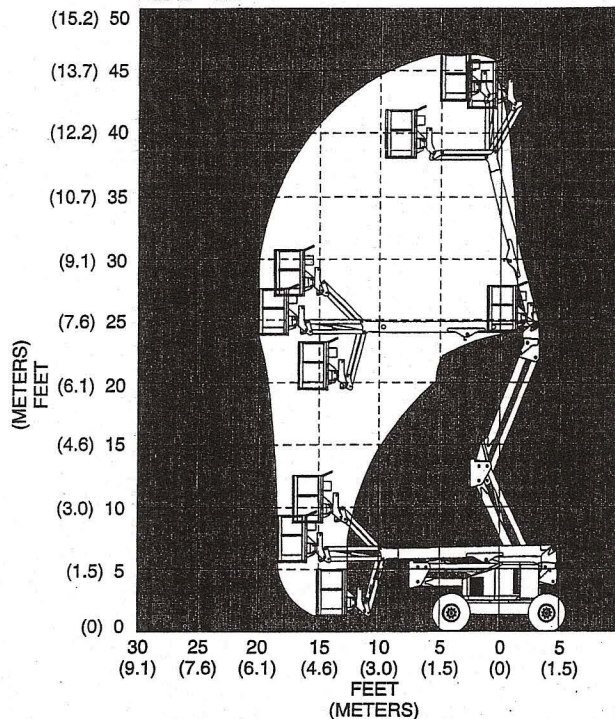

ATB 50

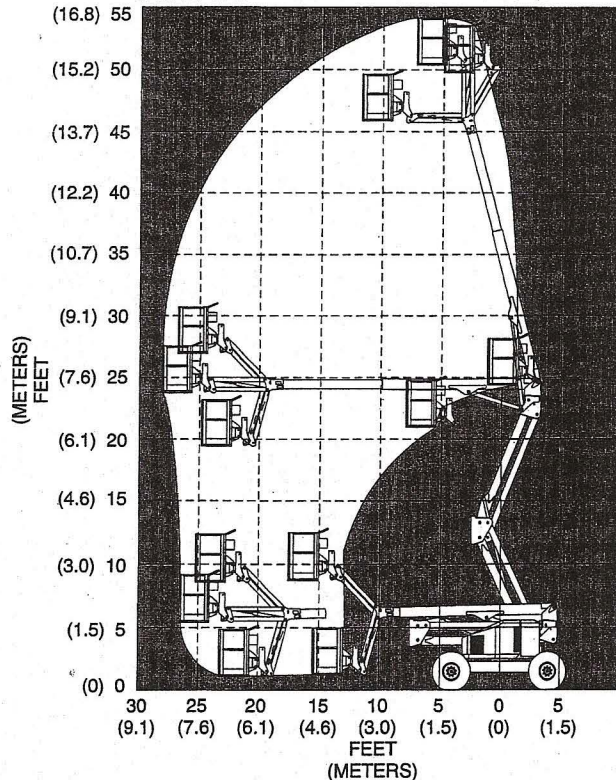

P.O. Box 4065, St. Joseph MO 64504-0065
 Phone: (816) 364-0317
 Fax: (816) 364-0380