

TIDD CRANE ///

NEW!



TIDD PC28

TRT ///
...for the long haul

www.trtaustralia.com.au

www.trt.co.nz



The new TIDD PC28 is the ultimate pick and carry crane for capacity, safety and comfort!

FEATURES

An articulating crane like no other, the TIDD PC28 is constructed using the highest quality components, and prioritises safety throughout its design.

The TIDD PC28 is the right crane for a wide range of operating environments with many class-leading features:

- European standard automotive finish
- Shortest forward projection in its class
- Outstanding turning radius

Full Power Boom

With the new 18.64m full power boom, a 75% stationary chart for the heavy lifts and 66% pick and carry chart, the Tidd PC28 packs a massive punch.

The high tensile steel, full power boom telescope Sections 1 and 2 are fully synchronised and provide hook compensation. Telescope Section 3 is independently operated with its own hydraulic cylinder.

Huge Lift Capability

With a 28 tonne maximum lift on the lug and 27.6 on the hook block. The TIDD PC28 delivers outstanding lifting capacities for improved efficiency and greater lift options, setting a new benchmark in the industry.

Moving from the stationary chart to the pick and carry chart is as simple as turning off the hold brake. You can now lift more and move more safely without compromise!

The Ultimate in Comfort

From the ergonomically designed forward mounted ROPS cabin (Patent No. 2012203625), with two-door configuration and ducted air conditioning, to the 150kg rated air suspension seats and 3-point safety belts, this crane is designed for comfort over long hours, helping to reduce operator fatigue!



Superior Road-ability

Get from site to site with ease with a maximum speed of 80km per hour (speed limited). It has full ABS braking for improved safety, whether the crane is operating while stationary or at speed.

Driven by a Mercedes Benz 6 cylinder turbo charged engine, and superior suspension, the TIDD PC28 is 12 tonne per axle on the road including its 2.3 tonne removable counterweight mounted on the front.

Focused on Safety

The TIDD PC28 is the only pick and carry crane with this level of safety. Designed to maximise safety, the crane will minimise risk on the work site and on the road. Safety features include Dynamic LMI with a deadlock switch inside the cabin. The LMI bridging switch is outside the cabin. Slew Safe™ is an optional safety addition, recommended for the TIDD PC28.

Manufactured for the Industry

TRT have been designing and manufacturing heavy equipment, cranes and trailers for over 50 years, with real expertise in crane design, TRT is the home of the TIDD Crane.

Many of the TIDD PC28 features are designed based on industry feedback, improving safety and focused on capability, by drawing on technology and knowledge from our renowned manufacturing capability. TRT's manufacturing operation is ISO9001-2015 accredited.



Slew Safe™

Exclusive to the TIDD Crane, Slew Safe™ can eliminate pick and carry crane rollovers, which are costly to operations.

This simple and effective system restricts the driver from operating off the chart. With audible and visual alarms along with steering restrictions, Slew Safe™ can't be over-ridden but will operate again when the load is back in the green. This sets a new standard in safety and industry best practice!

Australian Innovation Patent No. 2019100317

2.3 tonne roadable, front and rear mount counterweight.



3 emergency stop buttons, in cabin and either side of the crush zone in articulation area.

+

LMI override key is located outside behind the cabin.



Mirrors - placement for optimised visibility.



TIDD
CRANE IIII

1 tonne capacity carry deck with restraint points.



6.12-18.64m high tensile with 4 telescope sections.



Articulating 44° either side of centre.



Certified ROPS, 2-person cabin, seats have integrated seatbelts. Double door access.



Mercedes Benz OM906 six-cylinder, diesel engine.



27.6 tonne capacity on running rope.

25 tonne capacity.

28 tonne capacity on fixed lug (stationary)



DIMENSIONS

CAPACITY

- 28 tonne capacity on fixed lug
- 27.6 tonne capacity on running rope
- 25 tonne capacity pick and carry on lug

BOOM

- 6.12-18.64m high tensile steel
- 4 section full power boom

ARTICULATION

- 44° either side of the centre

SPEED

- Max 80km/hr

MASS

- Gross vehicle mass 23.9 tonne
- Front axle mass 11.9 tonne
- Rear axle mass 12 tonne

COUNTERWEIGHT

- 2.3 tonne roadable, front and rear mount

TIDD
CRANE IIII

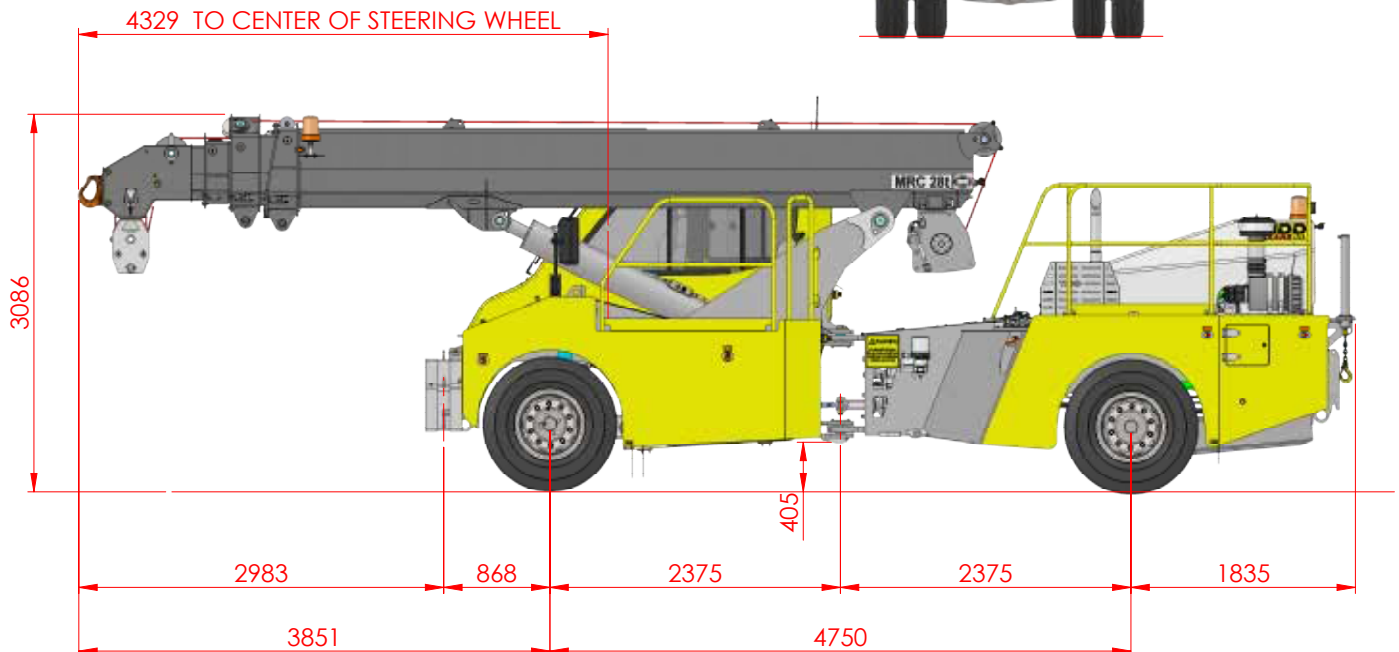
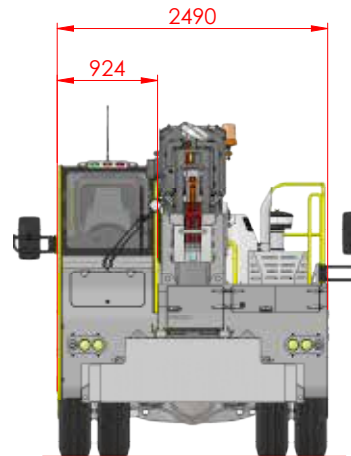
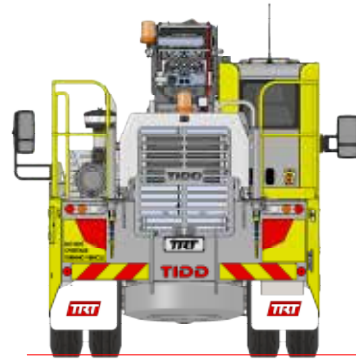
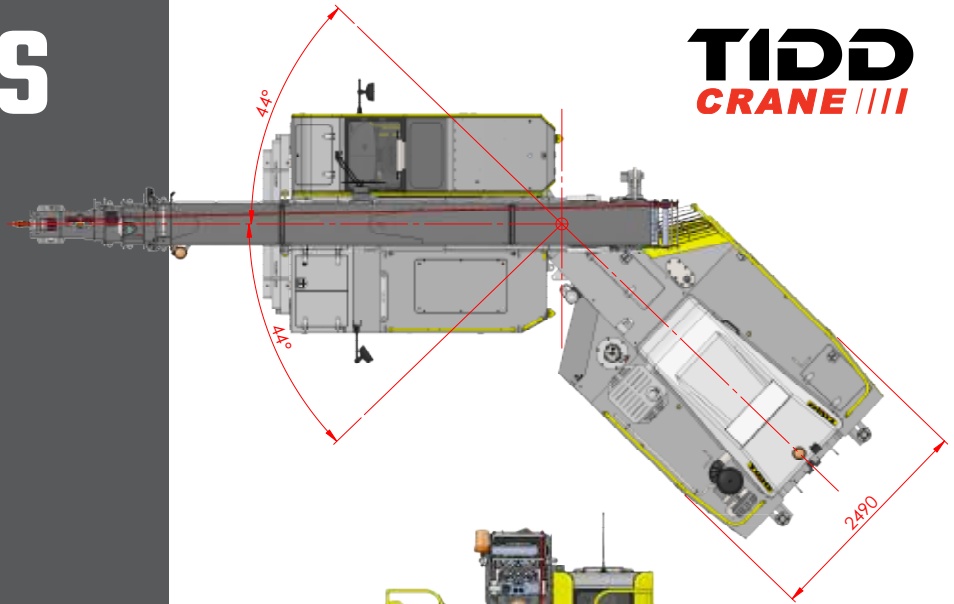

SPECIFICATIONS



The TDD PC28 is built with specialist features for construction and mining. There are a wide range of options available to tailor the crane to your operation. If the options you require are not listed below, please contact one of our experts.

CRANE

Double acting hydraulic cylinders (-6 to + 65°) with integral holding valve, allowing rigging to drop straight into the front chain box from the hook.	15 tonne capacity Rhino hook.
Anti-two block device.	4.6 tonne line pull Braden PD15 2-speed winch with automatic disc brakes and third wrap indicator.
Robway RCI8510 Dynamic Load Indicator with automatic cutouts and digital display.	14mm non-rotating wire rope x 6 falls.
A dash mounted deadlock switch allowing a temporary increase to 110% RC only with reduced function speeds.	15 tonne capacity spreader bar.
A key locked Bridging switch is mounted externally on the cab limiting access to authorised persons.	Large 2-sectioned chain box at the front of the crane and accessed directly from the hook.
Joystick control of boom and winch functions with 2-speed winch button, boom-telescoping switch proportionally controlled, and boom luffing with dead man trigger on grip.	1 tonne capacity carry deck with restraint points.
	Two work lights on the boom and one rotating beacon on the boom and engine cover.
	Three emergencies stop buttons, in cabin and either side of the crush zone in the articulation area.
	Tri light safe load indicator on cabin roof with audible alarm.
	CraneSafe inspection.
	1 year warranty standard.

OPERATOR

Forward mounted cabin provides excellent vision.	Hand rails and access steps all have 3 points of contact at all times.
Certified ROPS, 2-person cabin with double door access. (Patent No. 2012203625).	Safety glass throughout.
2 x 150 kg rated air suspension seats with 3-point seat belts.	1.5 kg fire extinguisher.
Large dry storage area via the hinged cabin steps, ideal for storing soft slings.	Mirrors - placement for optimised visibility.
	Reversing camera and alarm.
	Air conditioning.
	Bluetooth, Radio and USB Port.

RECOMMENDED OPTIONS

Slew Safe™ - Recommended - An effective system to restrict the driver from operating off the chart. With audible and visual alarms along with steering restrictions, Slew Safe cannot be over-ridden but will operate again when the load is back in the green. Accepted on many Tier 1 sites, as standard. (Australian Innovation Patent No. 2019100317)

Traction Air™ CTI - Recommended - TRT's Tyre pressure management system to improve crane safety on varying road surface, maintaining the correct tyre pressure at all times. Backed by a 3 year/500,000km warranty. Contact us for more information.

DRIVELINE

Mercedes Benz OM906 six-cylinder, 6.4 litre, turbo charged, intercooled 205 kW diesel engine.	Holding brake for front right wheel to allow slewing during stationary lifting.
Allison 3000 series automatic transmission, 6 speeds forward.	Beka Max™ Auto Grease Pump.
Kessler high-speed planetary axles with diff lock on front axle.	TIDD hydro-pneumatic suspension on the front axle with hydraulic lockout for crane mode and automatic height adjustment for road mode.
Meritor transfer case.	Heavy duty parabolic spring suspension on rear.
Two stage engine and exhaust brake.	High quality load sensing piston pump for hydraulic system, 305 litre hydraulic tank with filtration byway of pressure and return line filtration.
410 litre fuel tank with locking cap.	Battery isolator, external jump start terminals and starter isolator as standard.
Automatically activated emergency hydraulic steering.	LED 24V lighting system
Dual line full air brakes on all wheels with ABS.	Right side rear handrail for safe servicing of the engine area.
Pneumatically released spring applied emergency / park brake on all wheels.	

ADDITIONAL OPTIONS

Crane	25 degree offset Rhino attachment.
	Winch camera.
	1.9m offset Fly Jib with 0, 20 and 40 degree offsets.
	9.2t capacity single sheave hook block.
	Spare tyre and wheels.
Driveline	Spare tyre and wheel assembly mounted under rear chassis for safe easy access
	Super lift counterweight – releasing soon.
	Loose wheel-nut indicator.
	Exhaust spark arrestor.
	Fast fill options; engine and transmission oil, hydraulic oil only and fuel only.
Operator Comfort/Safety	FOPS certified top view glass.
	Refrigerated compartment under dogman seat.
	First aid kit.
	4.5kg or 9kg fire extinguisher left chassis mounted.
	Fire suppression system.
	UHF Radio.
	High visibility reflective tape striping to specification.
Rear handrail – left side.	

WORKING RANGE



With counterweight on rear

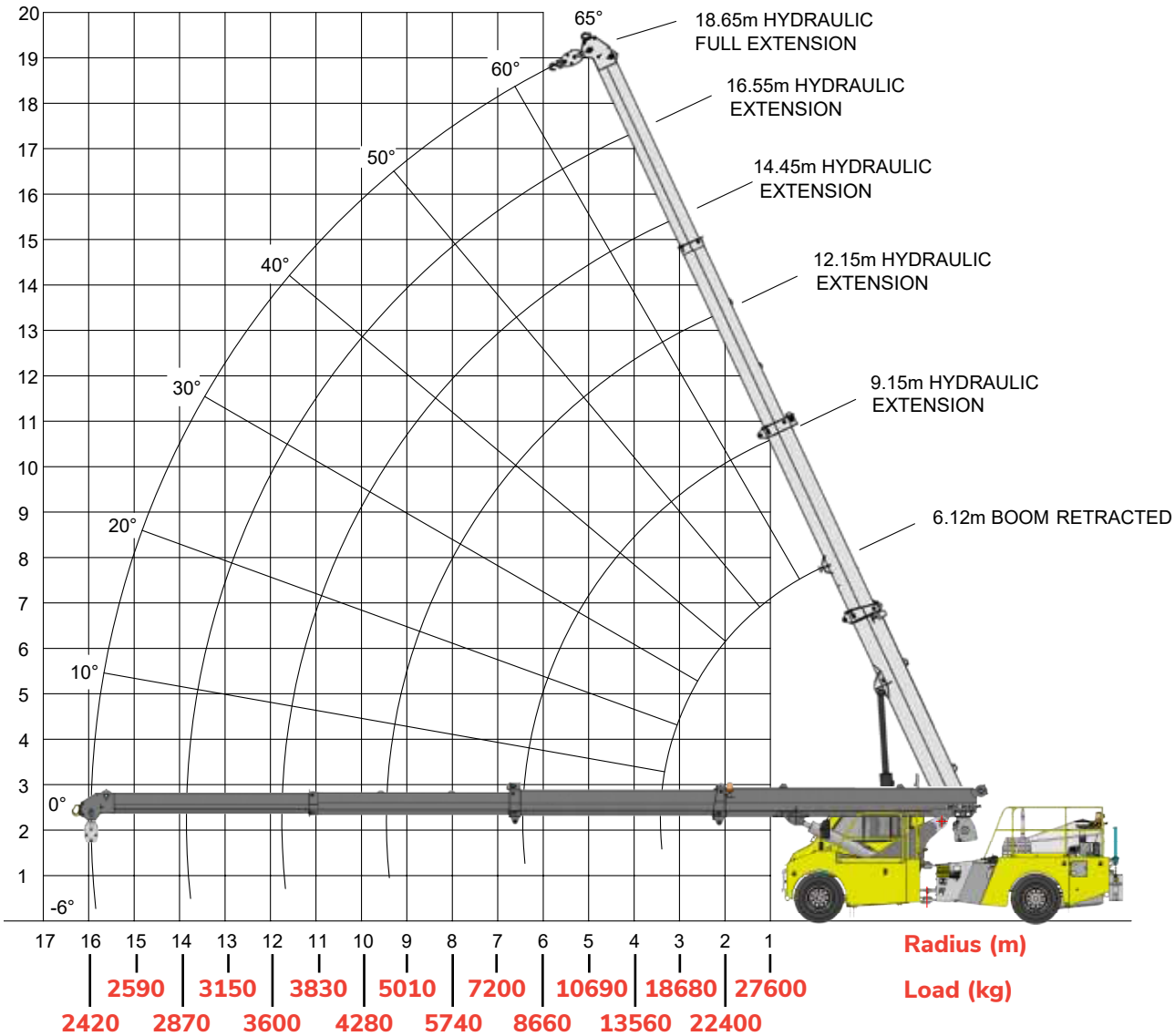

NOTE: Rated capacity values shown are for the stationary chart on the hook.

After Sales Support

TRT is proud to manufacture the TIDD PC28, and we are committed to supporting our product for its warranty and beyond. The team of highly experienced TIDD service technicians and agents are available to assist operators, fleet owners and workshops with training, advice, documentation and product upgrades.

Parts

TRT stocks genuine spare parts for the TIDD PC28 in Australia and NZ. We can easily arrange overnight freight for all spares and service items to ensure the Crane is returned to service with minimal downtime.

Distributed by:

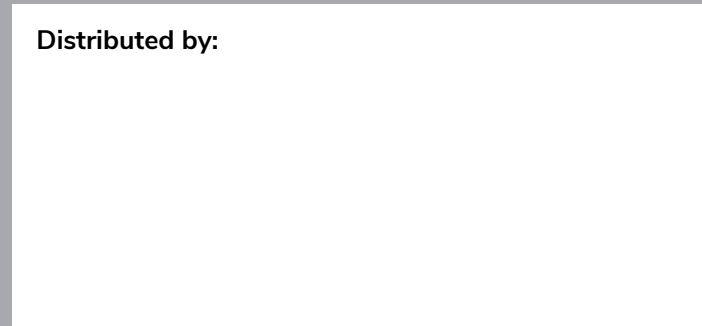

TRT reserves the right to alter specifications without notice. Photographs and drawings in this document are for illustrative purposes only. Product shown in photos contains optional features. TRT in so far as it is permitted by law to do so, shall not be liable in any way as a result of any reliance by any person on anything contained in this brochure.

Please contact us for current and detailed specifications. TRT Australia Pty Ltd / Tidd Ross Todd Ltd is the manufacturer of the TIDD PC28.

02082019

Designed & Manufactured by:



TRT (AUST) PTY. Ltd.
 1028 Lytton Road, Murarrie, QLD 4172
 Phone: +61 7 3890 8800
 Email: cranesales@trtaust.com.au
www.trtaustralia.com.au

Tidd Ross Todd Ltd
 48 Maui Street, Pukete Industrial Estate
 P.O Box 10076, Te Rapa, Hamilton 3241
 Phone: +64 7 849 4839 Email: cranesales@trt.co.nz
www.trt.co.nz